



## **NEWS RELEASE**

18 February 2009

### **New code of practice for raised timber decks endorsed by NHBC**

The Timber Decking Association (TDA) has announced the publication of a new Code of Practice (CP) for the design and construction of raised timber decks. The CP has been produced to help raise the standard of deck design and construction amongst homebuilders and is tailored specifically to the quality and performance requirements expected by the National House-Building Council (NHBC), the UK's leading standards setter and insurer of new homes.

The CP provides homebuilders with guidance on the specifications required to create raised timber decks capable of delivering a service life of 60 years – a key requirement of the NHBC.

The development of the CP dates back to autumn 2007 when NHBC announced that it had major concerns about the quality and safety of the timber decks that were beginning to feature on new homes. At that time NHBC said it was minded to ban the use of wood as a structural material for any deck more than 600mm from the ground. According to Steve Young, operations director of the TDA, it was important to correct perceptions that wood was no good as a structural material:

“ We were concerned that wood was being made something of a scapegoat for poor design, materials selection and installation practices. Our first priority was to get the NHBC to give wood the benefit of doubt and allow us to develop a code of practice that met their quality and performance requirements. We were the only timber industry body to lobby the NHBC on this issue and are delighted that they have accepted the TDA Code of Practice which will now become part of NHBC standards.”

The specifications in the CP provide for significantly increased load bearing and 60 year service life assumptions compared with current practice and this is reflected in the specifications recommended. Housebuilders will find detailed guidance about timber selection, component sizing, make up and spacing, footings and saddlestones, bracing, balustrades and stairs.

Code of Practice TDA/RD0801: *Raised Timber Deck Structures on new homes* is being made available free of charge as a pdf download to all NHBC Registered Builders, architects and professional building control officers.

“A Code of Practice like this would normally be sold for £30 or more. However, in the interests of good design and specification practice we are making it available free of charge to those organisations who have a major interest in getting it right first time” says Steve Young.

To obtain a copy, apply online via the architects help desk on [www.tda.org.uk](http://www.tda.org.uk)

ENDS

Further information contact: 01977 558147 Steve Young

The TDA’s code of practice contains detailed visuals, span tables and component specifications.

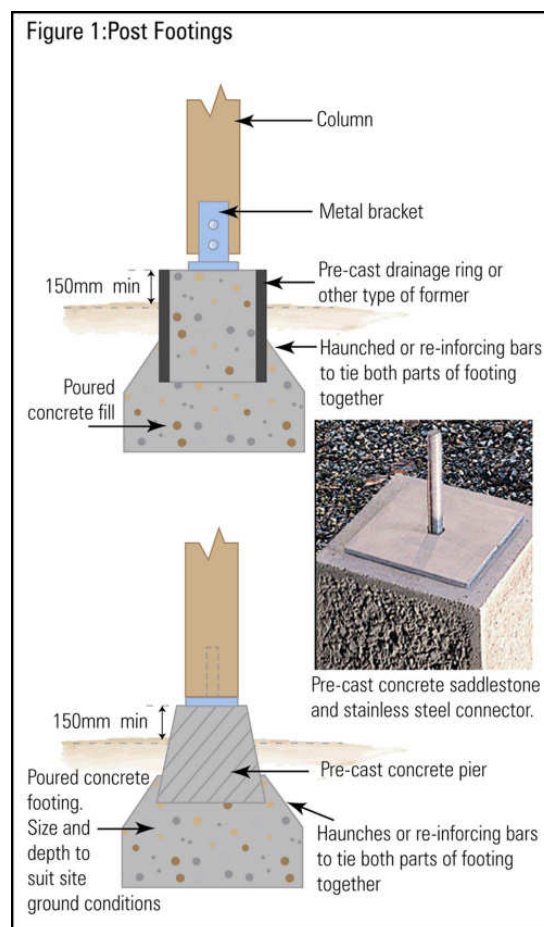

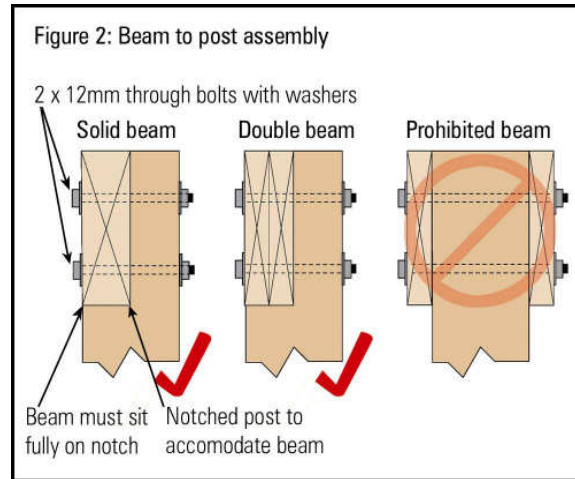

*Editors note: These visuals are available in jpeg format upon request.*

The Timber Decking Association is part of the  
 Timber Decking & Cladding Association Ltd.  
 5C Flemming Court  
 Castleford  
 West Yorkshire  
 WF10 5HW